



In partnership with



## Product Information

300.000.025

Version 02.2019

# Instantaneous safety gear RF braking downwards

Safety gear  
RF0010/RF0011





In partnership with



---

**Publisher** Sautter Lift Components GmbH  
Remsstraße 2  
70806 Kornwestheim | Germany  
Telephone: +49 (0) 7154.9996 - 0

Email: [sales@slc-liftco.com](mailto:sales@slc-liftco.com)  
Home: [www.slc-liftco.com](http://www.slc-liftco.com)

**Licence** Manufactured under license of C. Haushahn GmbH & Co. KG (RF0001)

**Copyright** © 2019 Sautter Lift Components GmbH

This manual is protected by copyright for the publisher and all rights are reserved.

This manual may not be reproduced in any way or copied by means of electronical copying methods, either as a whole or in part, without written permission of the publisher. Translating the material also comes under the definition of copying.

Copyright as per DIN ISO 16016. Subject to modification.



In partnership with



## Table of content

|  |           |
|--|-----------|
| <b>1. Safety instructions</b>  | <b>5</b>  |
| 1.1 Designations and signs   | 5         |
| 1.2 Principle / intended use of the safety gear                            | 5         |
| 1.3 Selection and qualification of personnel / basic responsibilities      | 6         |
| 1.4 Safety instructions governing assembly and specific operational phases | 6         |
| <b>2. General notes</b>  | <b>7</b>  |
| 2.1 Designation  | 7         |
| 2.2 Advantage-Gain-Argument  | 7         |
| 2.3 Criteria for the selection of safety gears                             | 8         |
| 2.4 EU Type-Examination Certificate  | 8         |
| 2.5 Manufacturer of the safety gear  | 8         |
| <b>3. Technical Data</b>   | <b>9</b>  |
| 3.1 Boundary conditions  | 9         |
| 3.2 Dimensions   | 9         |
| 3.3 Range of application   | 9         |
| 3.4 Tripping   | 10        |
| 3.5 State of delivery  | 10        |
| <b>4. Dimensions</b>   | <b>11</b> |
| <b>5. Specification and function</b>                                       | <b>12</b> |
| 5.1 Specification of the safety gear                                       | 12        |
| 5.2 Function of the safety gear  | 12        |
| <b>6. Assembly</b>   | <b>13</b> |
| 6.1 Assembly of the safety gear to the lift car                            | 13        |
| 6.2 Adjustment of the safety gear  | 13        |
| <b>7. Commissioning</b>  | <b>14</b> |
| 7.1 Functional check   | 14        |
| 7.2 Check after braking  | 14        |
| <b>8. Maintenance</b>  | <b>15</b> |
| <b>9. Transport</b>  | <b>15</b> |
| <b>10. Annexe</b>  | <b>15</b> |

## 1. Safety instructions

This product information refers to the instantaneous safety gear type RF braking downwards and contains important information on correct and safe installation, putting into service, use and maintenance of the safety gear. Observing these instructions helps to avoid danger, to reduce repair costs and downtimes and to increase the reliability and life of the safety gear.

The product information has to be supplemented by instructions based on national rules and regulations concerning accident prevention.

The product information must always be available wherever the safety gear is in use. The manual must be read and applied by any person in charge of carrying out work with and on the safety gear.

In addition to the product information and to the mandatory rules and regulations for accident prevention in the country and place of use of the safety gear the generally recognized technical rules for safe and proper working must also be observed.

### 1.1 Designations and signs

The following designations and signs are used in this product information to designate instructions of particular importance:



#### DANGER

in this manual refers to the risk of death, heavy injuries and extensive damage if the required prevention measures are not taken.



#### WARNING

in this manual refers to light injuries or damage if the required prevention measures are not taken.



#### IMPORTANT

in this manual refers to important information about the product or is meant to attract the readers attention to important parts of the product information.

### 1.2 Principle / intended use of the safety gear

The safety gear has been built in accordance with current standards and the recognized safety rules. Nevertheless, its use may constitute a risk to life and limb of the user or cause damage to the safety gear and to other material property.

The safety gear must be operated in technically perfect condition only, in accordance with its intended use and with the instructions set out in this product information. Any functional disorders, especially those affecting the safety of the safety gear should therefore be rectified immediately.

The safety gear RF braking downwards is designed exclusively for preventing the fall of the lift car or counterweight. Using the safety gear for purposes other than those mentioned above is considered contrary to its designated use. The manufacturer cannot be held liable for any damage resulting from such use.

The risk of any misuse lies entirely with the user.

Operating the safety gear within the limits of its designated use also involves observing the instructions set out in this manual and complying with the inspection and maintenance directives.



In partnership with



Never make any modifications, additions or conversions that might affect safety without the supplier's approval!

Spare parts must comply with the technical requirements specified by the manufacturer. Spare parts from original equipment manufacturers can be relied to do so.

Adhere to prescribed intervals for routine checks and inspections!

For the execution of maintenance work tools and workshop equipment adapted to the task on hand are absolutely indispensable.

### 1.3 Selection and qualification of personnel / basic responsibilities

Any work on and with the safety gear must be executed by reliable personnel only. Statutory minimum age limits must be observed!

Employ only trained and instructed staff and set out clearly the individual responsibilities of the personnel for operation, set-up, maintenance and repair!

Make sure that only authorized personnel works on or with the safety gear!

### 1.4 Safety instructions governing assembly and specific operational phases

|                             |   |
|-----------------------------|---|
| <b>Assembly</b>             | Always wear personal protective equipment during assembly work.   |
| <b>Standard operation</b>   | Avoid any operational mode that might be prejudicial to safety!<br>Take the necessary precautions to ensure that the safety gear is used only when in a safe and reliable state!  |
| <b>Main-tenance</b>         | Ensure that the maintenance area is adequately secured!<br>For carrying out overhead assembly work always use specially designed or otherwise safety-oriented ladders and working platforms. Wear a safety harness when carrying out maintenance work at greater heights!<br>Before cleaning with water or detergents cover or tape up all openings which - for safety and functional reasons - must be protected against water or detergent penetration.<br>After cleaning remove all covers and tapes applied for that purpose!<br>Always tighten any screwed connections that have been loosened during maintenance and repair!<br>Ensure that all consumables and replaced parts are disposed safely and with minimum environmental impact! |
| <b>Gas dust steam smoke</b> | Carry out welding or grinding work on the safety gear only if this has been expressly authorized, as there may be a risk of explosion and fire!<br>Before carrying out welding or grinding operation, clean the safety gear and its surroundings from dust and other inflammable substances and make sure that the premises are adequately ventilated (risk of explosion)! When there is little space for working observe the national rules and regulations!   |
| <b>Oil grease etc.</b>      | When handling oil, grease and other chemical substances, observe the product-related safety regulations!<br>Be careful when handling hot consumables (risk of burning or scalding)!   |

## 2. General notes

The safety gear type RF is a safety device for lifts.

The single-sided acting safety gear prevents the car resp. the counterweight from falling downwards.

All safety devices are type-examined.

### 2.1 Designation

**RF.. - .** Instantaneous safety gear („RollensperrFangvorrichtung“)

**0010** Type 10

**0011** Type 11

### 2.2 Advantage-Gain-Argument

| Feature           | Advantage   | Gain  |
|-------------------|---|---|
| Safety gear       | <ul style="list-style-type: none"> <li>❖ Prevents inadmissible excess of car speed in the event of intact suspension means and unfavourable loading</li> <li>❖ Prevents free fall of the car in the event of broken suspension means</li> </ul> | <ul style="list-style-type: none"> <li>❖ Reduces the residual risk</li> </ul> |
| Braking downwards | <ul style="list-style-type: none"> <li>❖ Tripping effects by the overspeed governor or by a slack-rope tripping device</li> </ul>   | <ul style="list-style-type: none"> <li>❖ low installation cost</li> </ul>     |

In partnership with



### 2.3 Criteria for the selection of safety gears

|                              |
|------------------------------|
| Rail head width              |
| Load of safety operation P+Q |
| Counterweight mass           |
| Car speed                    |

### 2.4 EU Type-Examination Certificate

Certification no. of the EU Type-Examination Certificate:

| Type   | Certification no.       |
|--------|-------------------------|
| RF0010 | TÜV-A-AT-1-21-0663-EUFV |
| RF0011 | TÜV-A-AT-1-21-0664-EUFV |

### 2.5 Manufacturer of the safety gear

Manufacturer of the safety gear

**Sautter Lift Components GmbH**

**Remsstraße 2**

**70806 Kornwestheim | Germany**

Holder of type-examination certificate RF0010:

Sautter Lift Components GmbH

Remsstraße 2

70806 Kornwestheim

Holder of type-examination certificate RF0011:

Sautter Lift Components GmbH

Remsstraße 2

70806 Kornwestheim



#### IMPORTANT

EU type-examination certificates plus certificates of conformity are added to the delivery separately.

In addition the EU type-examination certificates can be downloaded on the homepage of SLC:  
[www.slc-liftco.com](http://www.slc-liftco.com)

### 3. Technical Data

#### 3.1 Boundary conditions

- ❖ The device is an instantaneous safety gear.
- ❖ Braking is caused by frictional force.
- ❖ The device is installed on the lift car.
- ❖ Connection to the car with screws M12.

#### 3.2 Dimensions

| Type   | Installation dimensions |        |        |       |
|--------|-------------------------|--------|--------|-------|
|        | Weight (pair)           | Height | Width  | Depth |
| RF0010 | 9,6 kg                  | 100 mm | 134 mm | 50 mm |
| RF0011 | 11,2 kg                 | 120 mm | 134 mm | 50 mm |

#### 3.3 Range of application

|                               | RF0010  |       | RF0011 |
|-------------------------------|---------|-------|--------|
| Min. width of running surface | 20 mm   |       |        |
| Rail head width               | 8-10 mm | 16 mm | 9 mm   |

| Tripping speed [m/s] | Max. total mass [kg] |              |               |               |              |
|----------------------|----------------------|--------------|---------------|---------------|--------------|
|                      | RF0010 (8mm)         | RF0010 (9mm) | RF0010 (10mm) | RF0010 (16mm) | RF0011 (9mm) |
| 0,20                 | 2 376                | 2 046        | 2 887         | 3 777         | 2 264        |
| 0,30                 | 2 331                | 2 008        | 2 832         | 3 706         | 2 221        |
| 0,40                 | 2 271                | 1 956        | 2 759         | 3 610         | 2 164        |
| 0,50                 | 2 198                | 1 893        | 2 670         | 3 494         | 2 095        |
| 0,60                 | 2 115                | 1 821        | 2 570         | 3 362         | 2 015        |
| 0,70                 | 2 024                | 1 734        | 2 460         | 3 218         | 1 929        |
| 0,80                 | 1 929                | 1 661        | 2 344         | 3 067         | 1 839        |
| 0,90                 | 1 832                | 1 577        | 2 225         | 2 912         | 1 746        |
| 1,00                 | 1 734                | 1 493        | 2 106         | 2 756         | 1 652        |



| Max. rated speed    | RF0001 and RF0002 |
|---------------------|-------------------|
| Car                 | 0,63 m/s          |
| Counterweight       | 1,00 m/s          |
| Max. tripping speed | RF0001 and RF0002 |
| Car                 | 1,00 m/s          |
| Counterweight       | 1,00 m/s          |

### 3.4 Tripping

The safety gear is operated by an overspeed governor or by a slack-rope tripping device.

When connecting the braking elements with the overspeed governor, observe that the speed governor rope attachment point the way until the braking elements are contacting the guide rail does not exceed 0.03 m.

The tripping force required in the individual case must be found at the lift installation, considering all components.

Standard EN 81 rules that for the tripping of safety gears twice the required tripping force has to be available.

### 3.5 State of delivery

The safety gear is delivered in completely pre-assembled condition.

Upon mounting strictly observe the specified clearance between guide rails and safety gear braking rollers (see chapter 6.2).



#### DANGER

Wrong setting of the safety gear can result in falling-down of the lift.

If a setting correction is exceptionally required, the setting has to be carried out only by specially trained personnel after consultation with the manufacturer.



#### WARNING

The manufacturer cannot be held liable for damages caused by unauthorized setting alterations.



#### WARNING

Before installing the safety gear on the lift car its type plate characteristics have to be compared with the lift characteristics. The type plate is mounted on the safety gear.

The safety gear must only be applied within the permission scope of application: see EC type-examination certificate "Scope of application", certificate no. (see chapter 2.4).

4. Dimensions

RF0010

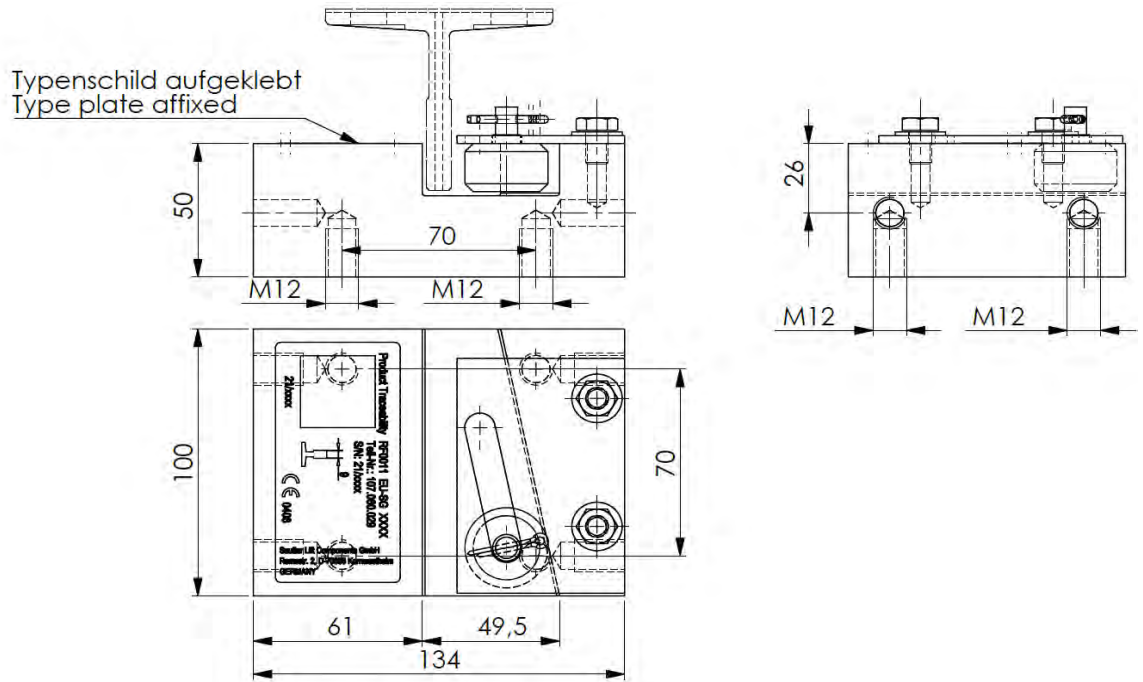

RF0011

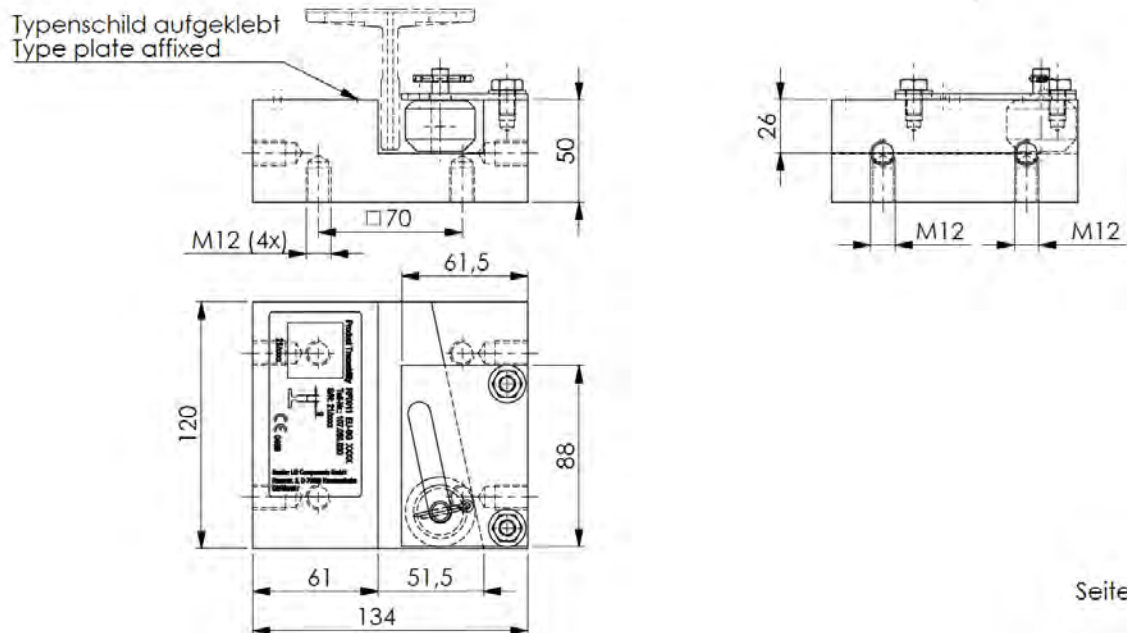

## 5. Specification and function

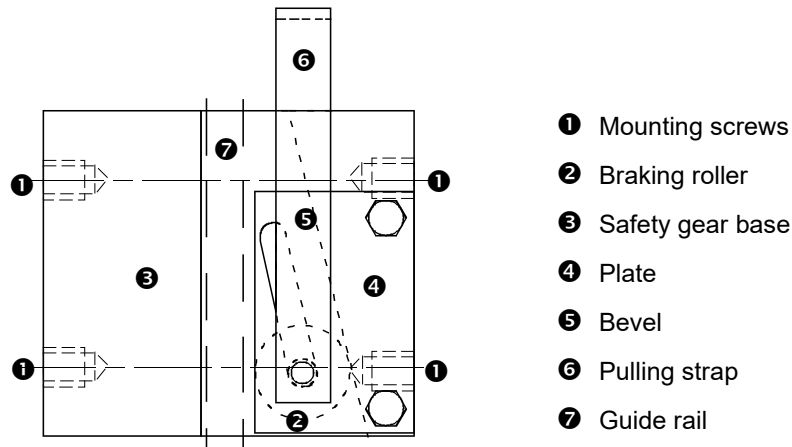

### 5.1 Function of the safety gear

#### Safety gear in idle position

If the operating linkage is adjusted properly the guide rail ❷ is freely movable between the safety gear base ❸ and the braking roller. ❷

#### Safety gear in blocking position

Upon tripping of the overspeed governor or rupture of the ropes the pulling strap ❻ is pulled upward by the operating linkage. The braking roller ❷, which is connected to the pulling strap, is pressed against the guide rail ❷ via the bevel ❺. The braking effect is achieved by friction between guide rail, braking roller and safety gear base.

The roller is released when the car is moved upward by mean of the lift drive.



#### IMPORTANT

The safety gear transfers braking forces to the lift car. Be aware of the braking forces in interface design.

## 6. Assembly

### 6.1 Assembly of the safety gear to the lift car

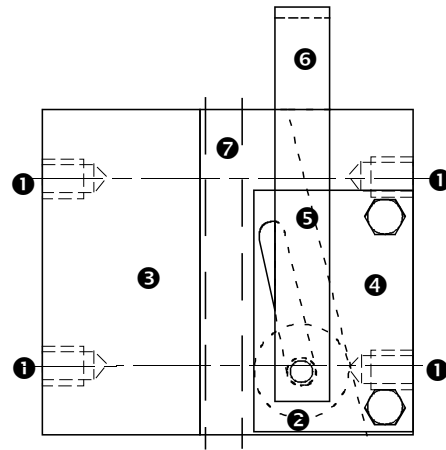

The safety gear must be mounted in pairs. They should be recessed into the structure, otherwise a limit stop shall be provided.

Four tapped holes M12 are provided for fixing.

The operating linkage is connected with the pulling strap.

### 6.2 Adjustment of the safety gear

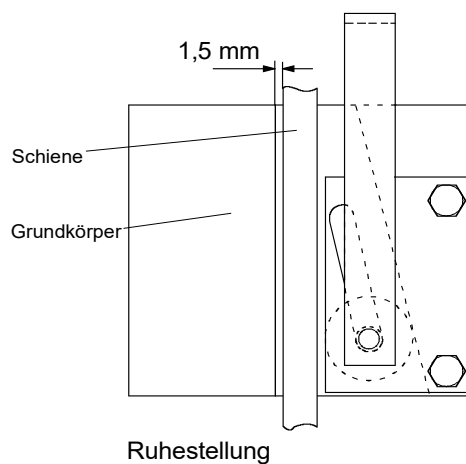

The knurled braking roller shall be in full contact with the guide rail blade.

The distance between the contact area of the safety gear base and the rail blade is to be adjusted to 1,5 mm.



#### WARNING

The actuating linkage is to be adjusted so that both brake rollers are simultaneously in contact with the guide rail.

The position of the safety gear is monitored via a positive-action switch.

## 7. Commissioning

### 7.1 Functional check



#### WARNING

Prior to commissioning the safety gear

- ❖ in connection with a slack rope device check whether the slack rope device functions properly and if the safety gear (rotary disc) is connected to the braking linkage.
- ❖ in connection with an overspeed governor check whether this one functions properly, if the safety gear is connected to the overspeed governor and if the generated tractive force corresponds with twice the force required for engaging the safety gear.

To check the correct assembly, the correct setting and the strength of the functional unit, consisting of the car with its decorative cladding, or the counterweight, safety gear, guide rails and their attachment to the building, the specifications in EN 81-20:2020,

- Appendix C.1 for the periodic inspection and
- Section 6.3.4 (test on the car) or 6.3.5 (test on the counterweight) for testing before commissioning or after a significant change

to be observed.

When the car / counterweight is pulled out of the blocking status, both brake rollers shall return automatically to their idle position.



#### WARNING

The safety gear may be operated only in combination with a slack rope device or an overspeed governor.

### 7.2 Check after braking

After every braking the safety gear has to be checked by a qualified person.

There is to be checked visually whether any changes or dirtying at the braking elements has occurred.

The following points are to be rechecked:

- ❖ Excessive wear of the braking rollers and the safety gear base
- ❖ Deformation
- ❖ Smooth running

The braking marks are to be grinded down.

Braking again on a re-grinded braking track is not causing an essential change of the braking force.



#### DANGER

For guide rail lubrication only oil products approved in the type examination certificate shall be used.

Use machine oil of viscosity class ISO 68-150 without extreme pressure additive. See mineral oils without additive (for example lubricant C according to DIN 51517, Part 1.)

Oils for hydraulic aggregates, gears and motors are not suitable for this use.

## 8. Maintenance

Upon maintenance (yearly) the safety gear shall be checked for:

- ❖ Ease of movement (function) through the manual actuation of the release linkage as well as the static lowering of the car / counterweight on the blocked safety gear
- ❖ synchronous operation of the two units
- ❖ wear
- ❖ rust
- ❖ dirt

If, after a couple of braking tests, the braking rollers or the safety gear base show signs of wear they are to be replaced by qualified persons.

The knurl on the catch roller must still be clearly visible or palpable with the fingertips.

## 9. Transport

Any work upon transport, storage, installation and commissioning as well as (if any) demounting and disposal of a safety gear is to be carried out by qualified persons only.

They shall be responsible for proper assembly, transport and installation, and for putting the safety gear into operational condition. If this is not ensured, the manufacturer shall not be held liable for any damages that might occur.

Upon transport the safety gear must be protected against:

- ❖ humidity
- ❖ shock
- ❖ dirt
- ❖ falling-down, etc.

## 10. Annexe

- ❖ EU type-examination certificate and certificate of conformity RF0010
- ❖ EU type-examination certificate and certificate of conformity RF0011