



In partnership with



Manual

300.000.181
Version 02.2019

Progressive safety gear BF_D-1

Safety gear

- ▶ Braking downwards
- ▶ Braking up and downwards
- ▶ Braking upwards



Safety gear tandem version

BF1D-1/BF1D-1

BF2D-1/BF1D-1



Safety gear triple version

BF1D-1/BF1D-1/BF1D-1

BF2D-1/BF2D-1/BF1D-1

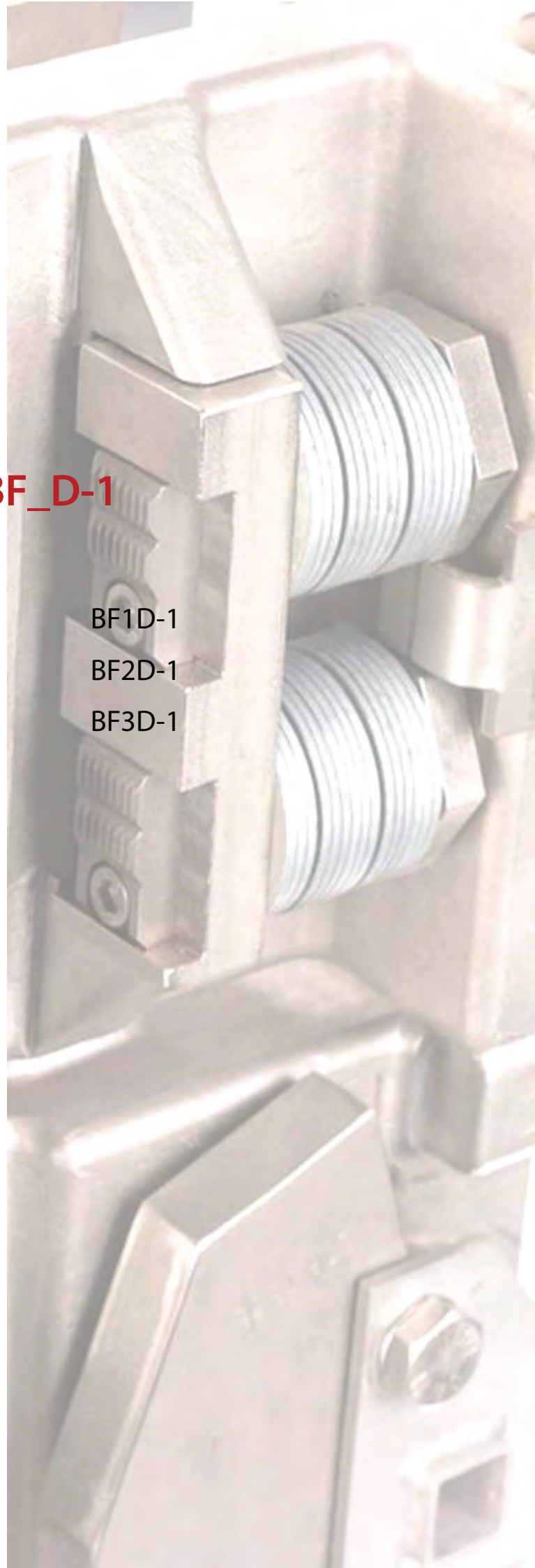

BF1D-1

BF2D-1

BF3D-1

Table of contents

1. Safety instructions.....3

1.1 Designation and signs..... 3

1.2 Principle / intended use of the safety gear..... 3

1.3 Selection and qualification of personnel / basic responsibilities..... 4

1.4 Safety instructions governing assembly and specific operational phases..... 4

2. General notes..... 5

2.1 Designation..... 5

2.2 Selection criteria for safety gears..... 5

2.3 EU type-examination certificates..... 5

2.4 Manufacturer of the safety gear..... 5

3. Technical data.....6

3.1 Range of applications..... 6

3.2 Application as part system of the protection device against unintended car movements..... 7

3.3 Tripping..... 9

3.4 State of delivery..... 10

4. Mounting and dimensions.....11

5. Specification and function..... 14

5.1 Specification of the safety gear..... 14

5.2 Function of the safety gear..... 14

6. Assembly.....15

6.1 Assembly of the safety gear to the lift car.....15

6.2 Synchronisation of the safety gear..... 16

7. Commissioning..... 17

7.1 Functional check..... 17

7.2 Acceptance test..... 17

7.3 Check after braking..... 17

8. Content of QR- code..... 18

9. Maintenance..... 19

10. Transport.....19

11. Annex.....19

Publisher Sautter Lift Components GmbH
 Remsstraße 2
 70806 Kornwestheim | Germany
 Phone: +49 (0) 7154.9996 - 0
 Email: sales@slc-liftco.com
 Home: www.slc-liftco.com

Licence Manufactured under license of C. Haushahn GmbH & Co. KG

Copyright © 2019 Sautter Lift Components GmbH

This manual is protected by copyright for the publisher and all rights are reserved.

This manual may not be reproduced in any way or copied by means of electronical copying methods, either as a whole or in part, without written permission of the publisher. Translating the material also comes under the definition of copying.

Copyright as per DIN ISO 16016. Subject to modification.

In partnership with



1. Safety instructions

This manual refers to the progressive safety gear BF type 2 and contains important information on correct and safe installation, putting into service, use and maintenance of the safety gear. Observing these instructions helps to avoid danger, to reduce repair costs and downtimes and to increase the reliability and life of the safety gear

The manual has to be supplemented by instructions based on national rules and regulations concerning accident prevention.

The manual must always be available wherever the safety gear is in use. The manual must be read and applied by any person in charge of carrying out work with and on the safety gear.

In addition to the manual and to the mandatory rules and regulations for accident prevention in the country and place of use of the safety gear the generally recognized technical rules for safe and proper working must also be observed.

1.1 Designation and signs

The following designations and signs are used in this manual to designate instructions of particular importance:



DANGER

In this manual refers to the risk of death, heavy injuries and extensive damage if the required prevention measures are not taken.



WARNING

In this manual refers to light injuries or damage if the required prevention measures are not taken.



IMPORTANT

In this manual refers to important information about the product or is meant to attract the readers' attention to important parts of the manual.

1.2 Principle / intended use of the safety gear

The safety gear has been built in accordance with current standards and the recognized safety rules. Nevertheless, its use may constitute a risk to life and limb of the user or cause damage to the safety gear and to other material property.

The safety gear must be operated in technically perfect condition only, in accordance with its intended use and with the instructions set out in this manual.

Any functional disorders, especially those affecting the safety of the safety gear should therefore be rectified immediately.

The safety gear **BF1D-1** is designed to prevent the car from falling (see EN81-20:2014-11, chapter 5.6:2:1 and EN81-1/2:1998 +A3: 2009, chapter 9.8)

The safety gear **BF2D-1** braking up- and downwards is designed to prevent the car from falling and as a protective device against overspeed for the upward-moving car (see EN81-20:2014-11, chapter 5.6:2:1 and 5.6.6 as well as EN81-1/2:1998 +A3: 2009, chapter 9.8 and 9.10)

The braking device **BF3D-1** braking upwards is designed as a protection device against overspeed for the upward-moving car (see EN81-20:2014-11, chapter 5.6.6 and EN81-1/2:1998 +A3: 2009, chapter 9.10)

All three variants act as a subsystem (braking element) of the protection device against unintended car movement (see EN81-20: 2014-11, chapter 5.6.7 and EN 81-1 / 2: 1998 + A3: 2009, chapter 9.11)

Using the safety gear for purposes other than those mentioned above is considered contrary to its designated use. The manufacturer cannot be held liable for any damage resulting from such use. The risk of any misuse lies entirely with the user.

Operating the safety gear within the limits of its designated use also involves observing the instructions set out in this manual and complying with the inspection and maintenance directives.

Never make any modifications, additions or conversions that might affect safety without the supplier's approval!

Spare parts must comply with the technical requirements specified by the manufacturer. Spare parts from original equipment manufacturers can be relied to do so.

Adhere to prescribed intervals for routine checks and inspections!

For the execution of maintenance work tools and workshop equipment adapted to the task on hand are absolutely indispensable.

1.3 Selection and qualification of personnel / basic responsibilities

Any work on and with the safety gear must be executed by reliable personnel only. Statutory minimum age limits must be observed!

Employ only trained and instructed staff and set out clearly the individual responsibilities of the personnel for operation, set-up, maintenance and repair!

Make sure that only authorized personnel works on or with the safety gear!

1.4 Safety instructions governing assembly and specific operational phases

Assembly	Always wear personal protective equipment during assembly work.
Standard operation	Avoid any operational mode that might be prejudicial to safety! Take the necessary precautions to ensure that the safety gear is used only when in a safe and reliable state!
Maintenance	Ensure that the maintenance area is adequately secured! For carrying out overhead assembly work always use specially designed or otherwise safety-oriented ladders and working platforms. Wear a safety harness when carrying out maintenance work at greater heights! Before cleaning with water or detergents cover or tape up all openings which - for safety and functional reasons - must be protected against water or detergent penetration. After cleaning remove all covers and tapes applied for that purpose! Always tighten any screwed connections that have been loosened during maintenance and repair! Ensure that all consumables and replaced parts are disposed safely and with minimum environmental impact!
Gas Dust Steam Smoke	Carry out welding or grinding work on the safety gear only if this has been expressly authorized, as there may be a risk of explosion and fire! Before carrying out welding or grinding operation, clean the safety gear and its surroundings from dust and other inflammable substances and make sure that the premises are adequately ventilated (risk of explosion)! When there is little space for working observe the national rules and regulations!
Oil Grease etc.	When handling oil, grease and other chemical substances, observe the product-related safety regulations! Be careful when handling hot consumables (risk of burning or scalding)!

In partnership with



2. General notes

2.1 Designation

BF.. - .	Progressive safety gear = B rems F angvorrichtung
1D	Braking in 1 direction (downwards) ↓
2D	Braking in 2 directions (up- and downwards) ↑↓
3D	Braking in 1 direction (upwards) ↑
- 1	Type 1
- 2	Type 2 (see manual 300.000.183)

Beispiel BF1D-2 = Progressive safety gear BF braking in 1 direction, Type 2

Type 1 and type 2 are different in construction of the counter brake shoe that affects the maximum load of the safety gear.

2.2 Selection criteria for safety gears

Rail head width			
Load of safety operation P+Q			
Counterweight mass			
Car speed			
Guide rail	→	machined	→ dry oiled
	→	drawn	→ dry oiled

2.3 EU type-examination certificates

Type	Certificate No.
BF1D-1, BF2D-1, BF3D-1	EU-SG 494/1



Please note:

Type-examination certificates according to 95/16 / EC can be downloaded on the homepage of SLC:
<http://www.slc-liftco.com/en/12/downloads.html>

2.4 Manufacturer of the safety gear and holder of the type-examination certificate:

Sautter Lift Components GmbH
 Remsstrasse 2
 70806 Kornwestheim, Germany

3. Technical data

3.1 Range of applications

	Machined rails		Drawn rails	
	dry	oiled ¹	dry	geölt ¹
All types				
Min. width of running surface	20 mm			
Rail head width	9 - 30 mm			
BF_D-1				
Max. rated speed [m/s]	2.62		2.16	
Braking force acting upwards F* [N]	8'322 – 41'330			
Braking force acting downwards [N]	8'322 – 41'330			
Max. load braking downwards P+Q [kg]	530 – 2'633			
BF_D-1/BF_D-1				
Max. rated speed [m/s]	2.62		2.16	
Braking force acting upwards F* [N]	8'322 – 82'660			
Braking force acting downwards [N]	8'322 – 82'660			
Max. load braking downwards P+Q [kg]	1'060 – 5'266			
BF_D-1/BF_D-1/BF_D-1				
Max. rated speed [m/s]	2.62		2.16	
Braking force acting upwards F* [N]	8'322 – 123'990			
Braking force acting downwards [N]	8'322 – 123'990			
Max. load braking downwards P+Q [kg]	1'590 – 7'899			
Use against unintended movement of the car (A3, UCM)				
Max. rated speed ² [m/s]	2.2 Application against unintended movement of the car (not to be mistaken for the maximum permissible rated or tripping speed)			
¹ The indications for oiled guide rail refer to use of mineral oils without additive (for example lubricant C according to DIN 51517, Part 1). ² Incl. increase of speed after tripping and after running through of braking element from normal position to acting position. This should be considered when used as a sub-system of the protection device against unintended car movement. This condition is assured with tripping speed max. 2.0 m/s of the part system 'tripping element' of the complete protection device, if the overspeed governor rope is actuated directly at the rotary disc or if the BF standard tripping devices (described in this manual) are used for actuating.				

Max. tripping speed of the overspeed governor and range of maximum rated speed:

Max. tripping speed [m/s]	2.16	2.62
Max. rated speed [m/s]	1.6 – 1.88	2.00 – 2.28

3.2 Application as part system of the protection device against unintended car movements

3.2.1 Determination of stopping distance

According to EN 81-20:2014-11, chapter 5.6.7.5 (EN 81-1:1998 + A3:2009, chapter 9.11 bzw. EN 81-2:1998 + A3:2009, chapter 9.13) the stopping distance is permitted to be max. 1200 mm, provided that an opening height of minimum 1000 mm between car and door frame remains. This means for a door height of 2000 mm the maximum stopping distance is 1000 mm. Using a system against unintended car movement the lift installer must assure compliance of the maximum stopping distance.

To comply with the requirements, the speed of the car at the time of the safety gear actuation may in this case not be greater than 2.2 m/s (see 3.1).

Using the safety gear type BF as part system of the protection device against unintended car movement both braking distance and distance of application of the safety gear assembly must be considered. The safety gear assembly consists of safety gear and tripping device.

a) Determination of distance of application

In case of actuating directly at the rotary disc a distance of application of 24 mm must be considered.

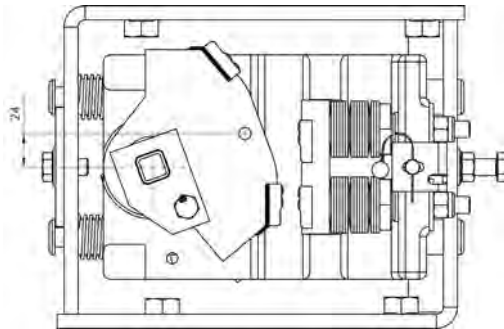

Pict. 1: Distance of application for safety gear actuated directly at rotary disc

In case of using a tripping device this value is increased.
In the next picture a side-mounted tripping device is shown:

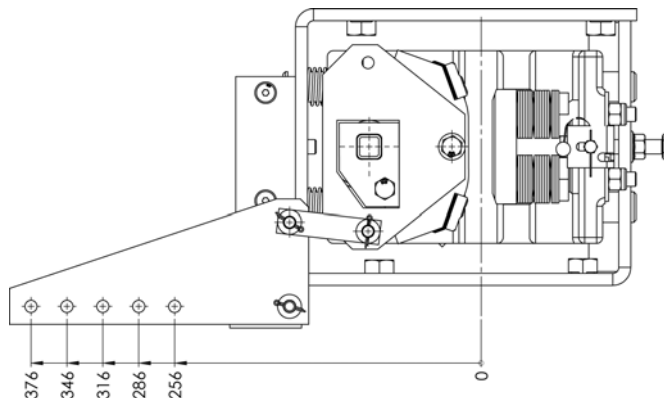

Pict.2: Standard tripping device

b) Determination of complete stopping distance caused by safety gear

Distance of application and braking distance must be added to determine the complete stopping distance. Using a tripping device 'side-mounted', assembled at outer housing with a distance of 216 mm to middle of guide rail, following stopping distance in downward direction results:

$$s = \text{distance of application} + \text{braking distance}$$

This value applies for maximum permissible speed of 2.2 m/s.
For slower speeds shorter stopping distances are valid correspondingly.

Please note:

Above determined stopping distance is only valid for the part system 'braking'.

To calculate stopping distance of the complete system reaction times of detection element and of overspeed governor have to be considered and added.

3.2.2 Requirements and conditions

Due to the fact that this part system is just the braking system of the protection device against unintended car movement, the complete system of the protection device against unintended car movement must be complemented by the adequate systems for detection and tripping according to EN81/20:2014-11 (EN81-1/2:1998 + A3:2009).

The complete protection device according to EN81/20:2014-11 (EN81-1/2:1998 + A3:2009), consisting of detecting, tripping and braking component, must assure, that the values given in EN81/20:2014-11, chapter 5.6.5 (EN81-1/2:1998+A3:2009, chapter 9.11.5 and 9.11.6) are fulfilled. Dimensioning of the complete system to fulfill the required values is in the responsibility of the lift installer. For dimensioning the device as braking system, information of chapter 3.2 in this manual can be used auxiliary.

The forces applied to the guide rails in up and down direction must be safely carried by the guide rails (e.g. without sliding the guide rails up or down in their fixings).

In addition all operating conditions and limitations of use of the bi-directional acting progressive safety gear BF2D-1 according to EU type examination EU-SG 494/1 apply accordingly.

3.3 Tripping

Below the minimum tripping force (whithout tripping device) required to trip the safety gear:

Type	Braking	Braking upwards
BF1D-1	200 N	-
BF1D-1/BF1D-1	300 N	-
BF1D-1/BF1D-1/BF1D-1	400 N	-
BF2D-1	200 N	150 N
BF2D-1/BF1D-1	300 N	175 N
BF2D-1/BF2D-1/BF1D-1	400 N	175 N
BF3D-1	-	150 N

The maximum admissible tripping force required at the safety gear shall not exceed 1'600 N.

The individually needed tripping force has to be ascertained at the lift, considering all components.

Standard EN81-20:2014-11 rules that for the tripping of safety gears twice the required tripping force has to be available - at least 300 N!

In partnership with



3.4 State of delivery

The safety gear is adjusted by the manufacturer to the following lift specific characteristics:

- ❖ Mass of lift car (P)
- ❖ Mass of payload (Q)
- ❖ Mass of compensation ropes
- ❖ Rated speed of lift car
- ❖ Rail head width (9 – 30 mm)
- ❖ Manufacturing mode of rails (machined, drawn)
- ❖ Surface condition of rails (dry, oiled)

The setting is secured against alterations by the manufacturer by means of a seal.



DANGER

Incorrect setting of the safety gear can cause a crash of the elevator.

The safety gear is adjusted by the manufacturer. As the deceleration depends on different, partially lift-specific factors (material of guide rail, surface hardness of the rail, ...) a precise pre-adjustment cannot be guaranteed.

If a setting correction is exceptionally required, the setting has to be carried out only by specially trained personnel after consultation with the manufacturer SLC. The new setting has to be secured against unauthorized alterations by means of a seal.



WARNING

The manufacturer cannot be held liable for damages caused by unauthorized setting alterations.



WARNING

Before installing the safety gear on the lift car its type plate characteristics have to be compared with the lift characteristics. The type plate is mounted on the safety gear.

The safety gear must only be applied within the permission scope of application: see EU type-examination certificate "Scope of application", certificate no. see chapter 2.3.



IMPORTANT

The safety gear is set at work according to values specified in the order form for safety gears to obtain the required braking force.

In addition, the order form can be downloaded on the homepage of SLC:

<http://www.slc-liftco.com/en/12/downloads.html>

4. Mounting and dimensions

Mounting of the safety gear

Braking downwards

Braking up- and downwards

Braking upwards

BF1D-1

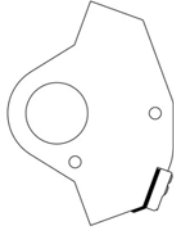

BF2D-1

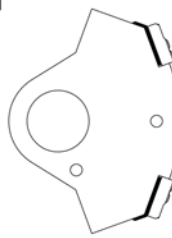

BF3D-1



Specification of the safety gear

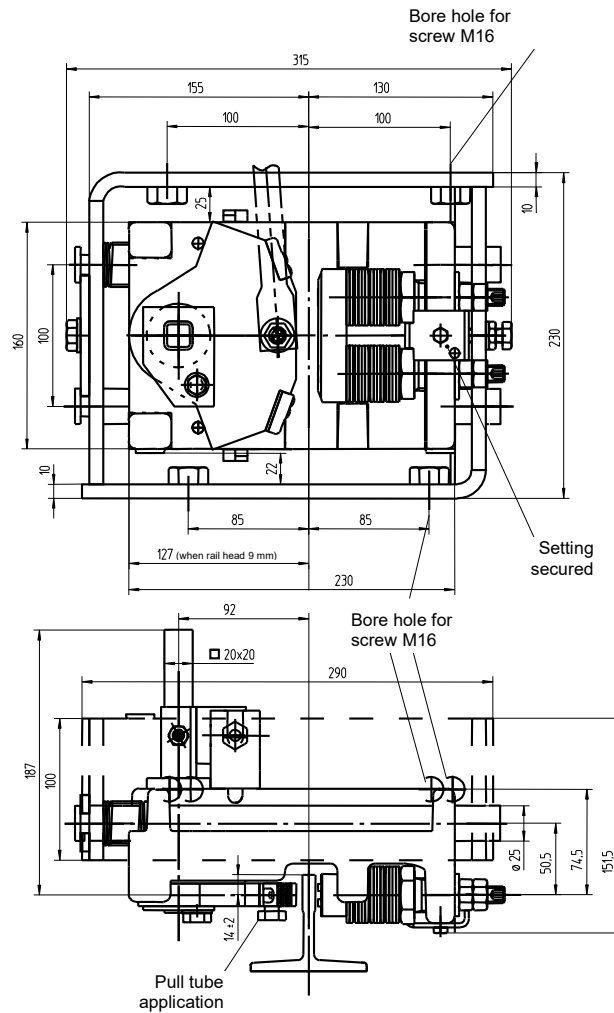

Type	Installation dimensions with outer casing				Installation dimensions without outer casing			
	Weight (Pair)	Height	Width	Depth	Weight (Pair)	Height	Width	Depth
Standard	45 kg	230 mm	300 mm	152 mm	25 kg	160 mm	230 mm	95 mm
Tandem	100 kg	415 mm	420 mm	212 mm	50 kg	330 mm	230 mm	95 mm
Triple	150 kg	560 mm	420 mm	212 mm	75 kg	500 mm	230 mm	95 mm

In partnership with



Tripping device

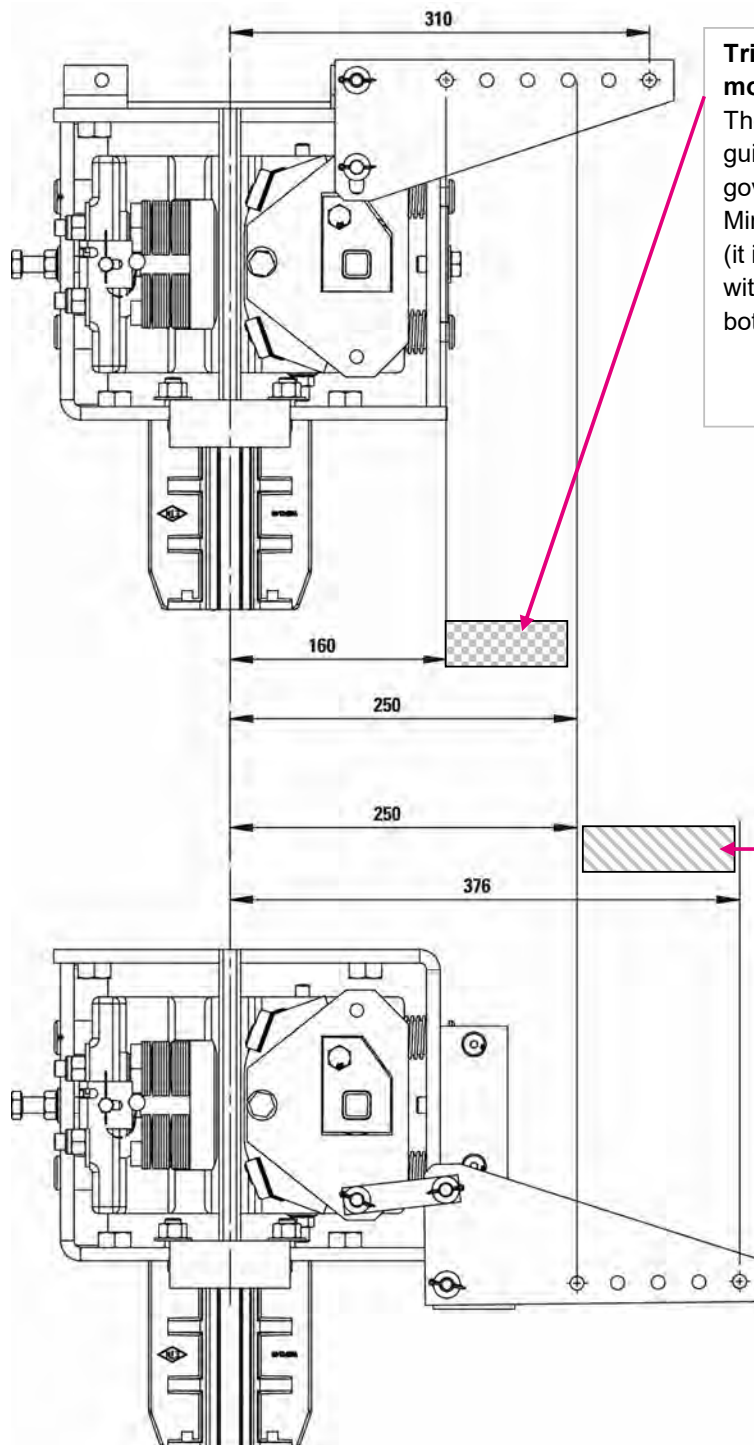

Tripping device mounted top/ bottom:

The distance between center of the guide rail and first over-speed governor rope:
 Min. 160 mm and max. 250 (310) mm
 (it is not available for outer housing with customized mounting holes on both sides!)

Tripping device side mounted:

The distance between center of the guide rail and first overspeed governor rope:
 Min. 250 mm and max. 376 mm



IMPORTANT

Find more information about tripping device for safety gear type BF side mounted, mounted top/ bottom and triple on our homepage: <http://www.slc-liftco.com/en/12/downloads.html>

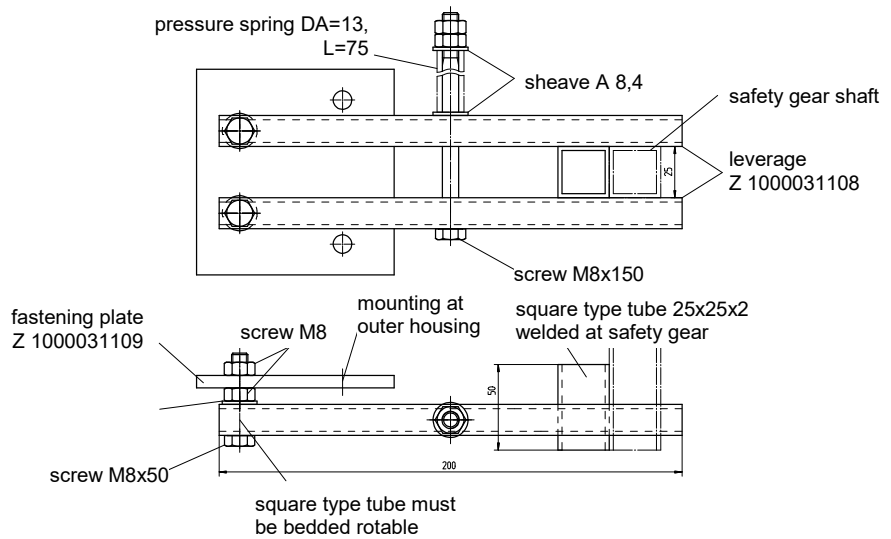
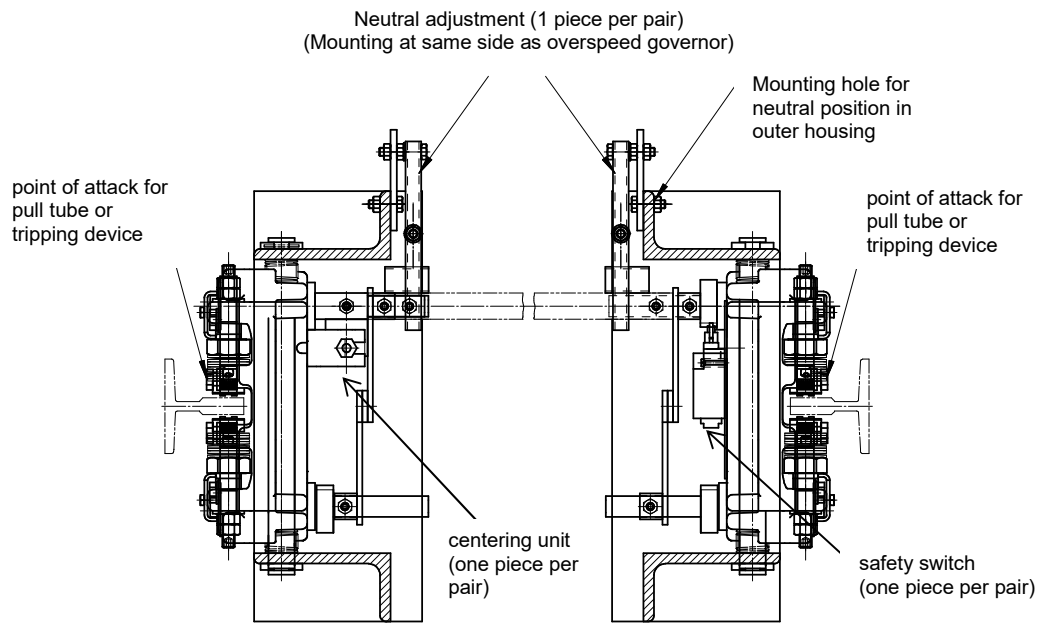

Accessories: Safety gear shaft bracket

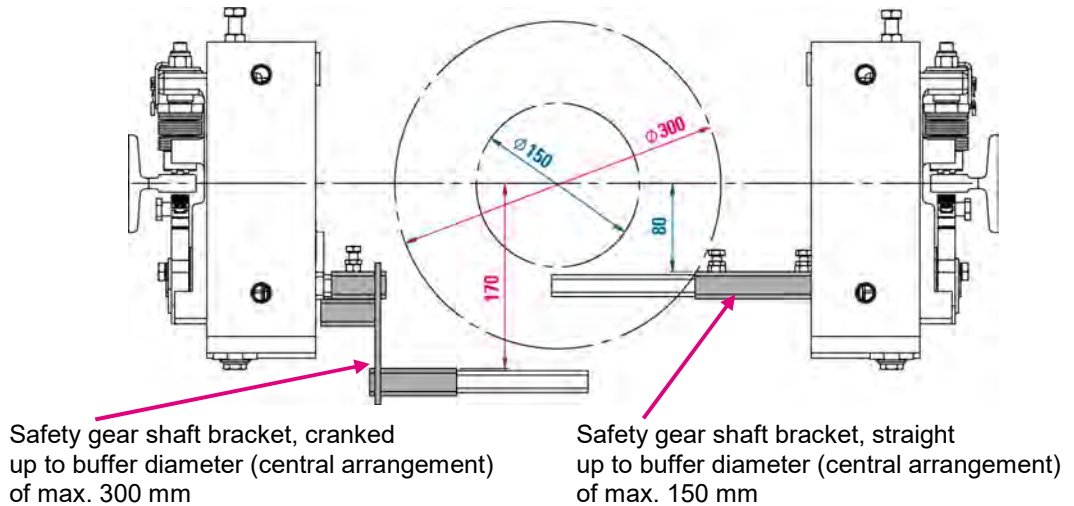

5. Specification and function

5.1 Specification of the safety gear

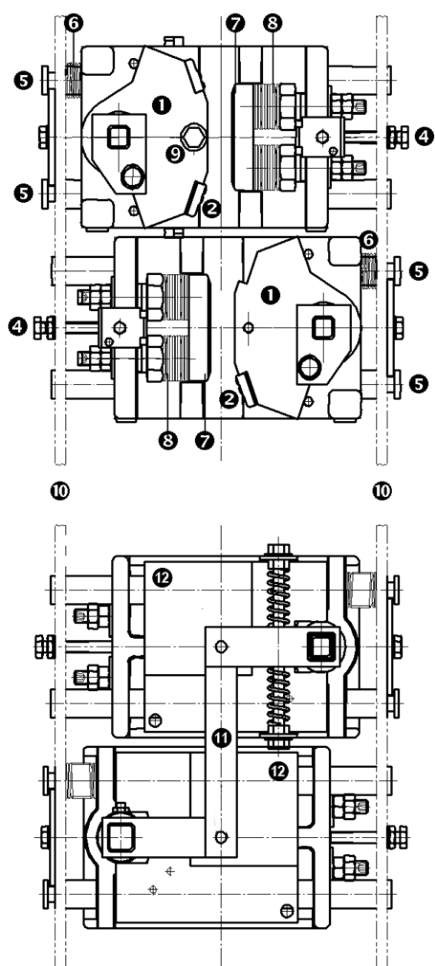

- ❶ rotary disc in neutral position
- ❷ brake shoe for downward braking with distance plates
- ❸ brake shoe for upward braking
- ❹ set screw for neutral position
- ❺ guide bolt
- ❻ reset spring (neutral position)
- ❼ counter brake shoe
- ❽ disk spring assembly
- ❾ Point of attack for braking linkage resp. overspeed governor rope
- ❿ outer housing
- ⓫ movable plate
- ⓬ type plate

5.2 Function of the safety gear

Upon tripping of the slack rope or overspeed governor both rotary discs ❶ synchronised by the actuating shaft, are turned by 20°.

In case of the tandem and triple version the synchronisation of the lower rotary disc is affected by a movable plate ⓫.

In the process the lower brake shoe ❷ respectively, situated on the rotary disc, moves against the rail surface. The cast housings move relatively to the lift car on guide bolts until the counter shoe ❼ touches the rail, pressing the disc spring assemblies ❽ together.

In the braking process the brake shoes fixed to the rotary discs cut into the rail surface. The braking effect is caused by metal cutting in the rail surface, friction and spring tensioning work. Moving the lift car opposite to the braking direction turns the rotary disc back in its neutral position.

The safety gear is ready again.



IMPORTANT

The safety gear transfers braking forces to the lift car. Be aware of the braking forces in interface design (see chapter 3.1).

6. Assembly

6.1 Assembly of the safety gear to the lift car

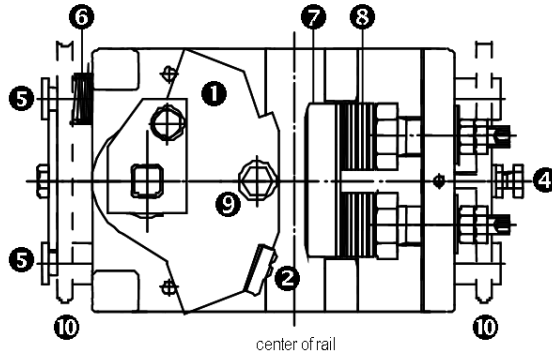

The safety gear has to be fixed to the lift car with guide bolts ⑤ or has to be suspended in an outer housing fixed to the lift car.

Number of bolts:

- ❖ 2 pieces/side for standard versions
- ❖ 4 pieces/side for tandem versions
- ❖ 6 pieces/side for triple versions

The guide bolts ⑤ have to be secured appropriately.

Determine the free bolt length between the casing and the support at the lift car or the outer housing so that the admissible tensioning stress for the bolt material is not exceeded when the safety gear is engaged (e.g. for pins of steel 1*0037: free bolt length < 40 mm). The bolts have to be protected

A spring ⑥, sitting on one of the bolts, presses the safety gear against a set screw ④. This keeps the progressive safety gear in neutral position



WARNING

The reset spring ③ has always to be mounted to that side of the rail where the rotary disc ① is. By means of set screw ④ the horizontal clearance between rail and brake shoe is adjusted.

The braking surfaces must be completely covered by the rail running surface.

The distance between the rail running surface and the large brake shoe ⑦ supported by the disk springs is adjusted to 2 mm.

The safety gear has to be installed such that the spring supported brake shoe ⑦ is in parallel with the rail and the travel direction, thus preventing an uneven braking trace.



WARNING

Make sure that the distance between safety gear (cast iron housing) in neutral position and outer housing is at least 7 mm.

Assembly position of the safety gear

During assembly take care that the safety gear is correctly positioned.

Between the brake shoes and the rotary disc one or more distance plates are inserted. This increases the spring travel and raises the braking force.

The brake shoe for braking downwards is underlaid with several distance plates, the brake shoe for braking upwards is normally underplayed with only one plate.

The distance plates under the brake shoe on the rotary disc are considerably projecting. The brake shoe on the rotary disc with the most distance plates, has to point downwards in neutral position.



WARNING

Check again the position of the distance plate when the safety gear is mounted to the lift car. Incorrect safety gear installation results in functional disorders of the safety gear.

Application with overspeed governor
(drawings see chapter 4)

Both safety gear units on a lift car are linked with an actuating shaft.

The actuating shaft is fixed to the safety gear with attachment screws. The actuating shaft is connected by means of two straight connecting tubes or two cranked brackets 25x25x2 mm.

❖ Connection via tension rod

The rotary disc is connected to the overspeed governor rope with a tension rod. The rod is fixed to the rotary disc by a screw M10 and a retaining washer. The tightening torque for this screw is 20 Nm.

When the overspeed governor is blocked the rod transfers the tractive forces from the governor rod to the rotary disc.

When braking downwards the lower brake shoe of the rotary disc is turned against the rail.

On dimensioning of the tension rod the tractive force has to be considered.

6.2 Synchronisation of the safety gear

Before commissioning the safety gear, the synchronisation of the safety devices have to be controlled. Important is the position of the rotary disc:

Incorrect position:



For manual engagement of the rotary disc turn the actuating shaft. If there is a gap between rotary disc and mechanical stop, the position has to be corrected until the gap is removed.

For correcting the position, the following steps have to be taken:

1. Dismantle the mounting screw M10 between lever and rotary disc.
2. Turn the rotary disc till the mechanical stop of the safety block, hold the disc in this position and tighten the mounting screw M10 again.
3. Test afterward by turning the actuating shaft if the rotary discs of the left and the right safety gear contact the safety block. If this is not the case, repeat the steps mentioned below till the synchronization is given.

Correct position:

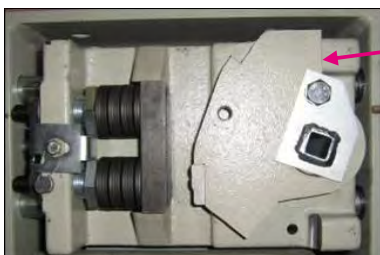

There is no gap between rotary disc and mechanical stop.

7. Commissioning

7.1 Functional check



WARNING

Prior to commissioning the safety gear

- ❖ the synchronisation is to be checked (see chapter 6.2)
- ❖ in connection with a slack rope device check whether the slack rope device functions properly and if the safety gear (rotary disc) is connected to the braking linkage.
- ❖ in connection with an overspeed governor check whether this one functions properly, if the safety gear is connected to the overspeed governor and if the generated tractive force corresponds with twice the force required for engaging the safety gear.
- ❖ the lift car has to be braked with low speed. It is to be checked whether both brake arms are swinging into their operation position

To check the braking force the safety gear can be tripped at rated speed or overspeed.

Upon pulling-out of the braking position the brake arm swings automatically into it neutral position.



WARNING

The safety gear may be operated only in combination with a slack rope device or an overspeed governor.

7.2 Acceptance test



IMPORTANT

Engagement test downwards

Tests before commissioning the lift according to EN81-20:2014-11, chapter 6.3 (EN81-1/2:1998+A3:2009, annex D) resp. periodic tests according to EN81-20:2014-11, annex C (EN81-1/2:1998+A3:2009, annex E).

7.3 Check after braking

The following points are to be rechecked:

- ❖ excessive wear of the brake shoes
- ❖ deformations
- ❖ smooth running

The rubbed-off particles have to be removed and the braking marks have to be grinded down.

Braking again on a re-grinded braking track is not causing an essential change of the braking force.



DANGER

For guide rail lubrication oil products approved in the type examination certificate shall be used only.

Use machine oil of viscosity class ISO 68-150 without extreme pressure additive. See mineral oils without additive (for example lubricant C according to DIN 51517, Part 1.)
Oils for hydraulic aggregates, gears and motors are not suitable for this use.

8. Content of QR-code

Description	Data field	Type	Length (symbol)	Safety components from other suppliers
1	Product name	CHARACTER	40	Product name of safety gear
2	Release	NUMBER	2	
3	Revision	NUMBER	2	
4	Identification number	CHARACTER	35	SL product number
5	Serial number	CHARACTER	18	
6	Batch number	CHARACTER	10	Only when serial number is not available
7	Manufacturer name	CHARACTER	30	Name of manufacturer
8	Manufacturer postal code	CHARACTER	10	Postal code of manufacturer
9	Manufacturer town	CHARACTER	30	Town of manufacturer
10	Manufacturer country code	CHARACTER	5	Two-character country code according to ISO 3166-1
11	Importer name	CHARACTER	30	Name of importer
12	Importer postal code	CHARACTER	10	Postal code of importer
13	Importer town	CHARACTER	30	Town of importer
14	Importer country code	CHARACTER	5	Two-character country code according to ISO 3166-1

Notice: Data fields without values are marked with "---". If numbers 2 and 3 (approval and revision) are not necessary, fields remain empty.

Example of QR-code for BF safety gear from SLC:

Description	Data field	Text in QR-code	Sample QR-code
1	Product name	BF2D-1	
2	Release		
3	Revision		
4	Identification number	847560	
5	Serial number	146493	
6	Batch number	---	
7	Manufacturer name	Sautter Lift Components GmbH	
8	Manufacturer postal code	70806	
9	Manufacturer town	Kornwestheim	
10	Manufacturer country code	DE	
11	Importer name	SLS Sassi Lift Systems	
12	Importer postal code	CM7 2QJ	
13	Importer town	Braintree	
14	Importer country code	GB	

9. Maintenance

Upon maintenance the safety gear shall be checked for:

- ❖ smooth operation
- ❖ synchronous operation of the two units
- ❖ wear
- ❖ rust
- ❖ dirt
- ❖ sealing

If, after a couple of braking tests, the braking rollers or the safety gear base show signs of wear they are to be replaced by qualified persons.

In case of replacing the brake shoes also the mounting screws have to be replaced.

Material no.:



Packing unit change of brake shoes **506.000.183**
for rotary disc
(type 1 and 2)

10. Transport

Any work upon transport, storage, installation and commissioning as well as (if any) demounting and disposal of a safety gear is to be carried out by qualified persons only.

They shall be responsible for proper assembly, transport and installation, and for putting the safety gear into operational condition. If this is not ensured, the manufacturer shall not be held liable for any damages that might occur.

- ❖ Upon transport the safety gear must be protected against:
- ❖ humidity
- ❖ shock
- ❖ dirt
- ❖ falling-down, etc.

11. Annex

- ❖ EU type-examination certificate
- ❖ Certificate of conformity



IMPORTANT

Find more certificates of conformity in additional languages on our homepage:
<http://www.slc-liftco.com/en12/downloads.html>.